

Side loader washer extractors

WS5200H, WS5270H, WS5350H

Features and benefits

- Side loader constructions with 2 industrial bearings for an unmatched lifetime
- External doors with vertical hinges and 175° opening, easy to handle and reversible
- Automatic drum positioning and locking for the loading and unloading operation, offering the best ergonomics and safety for the operators
- Large inner drum doors to make loading and unloading operations easier than ever
- Compass Pro® controller with a user friendly interface to make the operator's life easy allowing 40 factory and 15 customized wash programs
- Compatible with up to 13 detergent signals as standard to stand the most complicated wash programs
- Suspended construction allowing a 350G extraction to save energy during the drying process
- Feature the Power Balance from Electrolux that ensures the best extraction whatever the loading conditions are
- New lifters for a better wash result
- Easy program customization via the LPM software from Electrolux



Images shown are a representation of the product only and variations may occur.

Main options

- End of cycle alarm to save valuable process time
- 4 compartments soap box to use liquid or powder detergents
- Stainless steel body to better stand aggressive environments
- Integrated weighing system to optimize loading operations
- 3rd water inlet valve for soft water

Main specifications				WS5200H			WS5270H			WS5350H		
Max. capacity		kg/lb		20/44			27/60			35/77		
Drum, volume diameter	volume	litre		200			270			350		
	diameter	ø mm		770			770			770		
Extraction		rpm		910			910			910		
G-factor				350			350			350		
Heating alternatives, 380-400V	electricity	kW		13.5			18			27		
	steam (600 kPa)	kg/h		8			11			14		
	gas	Btu/h		136600			136600			136600		
Consumption data *				El	Steam	Gas	El	Steam	Gas	El	Steam	Gas
Water consumption (cold)			litre	213	213	233	308	308	328	426	426	446
Energy consumption (motor/heating)			kWh	11.3	0.4	0.5	12.7	0.45	0.57	18.6	0.5	0.65
Steam consumption (600 kPa)			kg	-	8	-	-	11	-	-	14	-

* With accordance to ISO 9398-4 Test cycle C.

Produced according to ISO 9001 and ISO 14001.

Certified with CB certificate for Low Voltage Directive and S-mark according to the Machinery Directive. Protection class IP X4D.

Electrical connections*					
Heating alternative	Main voltage		Heating power kW	Total power kW	Recommended fuse A
		Hz			
WS5200H					
Electric heated	400-415V 3 ~	50/60	13.5	15	32
Steam heated	400-415V 3 ~	50/60	-	6	16
Gas heated	400-415V 3 ~	50/60	40	6.3	16
WS5270H					
Electric heated	400-415V 3 ~	50/60	18	19.5	40
Steam heated	400-415V 3 ~	50/60	-	6.2	16
Gas heated	400-415V 3 ~	50/60	40	6.5	16
WS5350H					
Electric heated	400-415V 3 ~	50/60	27	28.8	50
Steam heated	400-415V 3 ~	50/60	-	6.4	16
Gas heated	400-415V 3 ~	50/60	40	6.7	16

Water, steam, gas and air connections		WS5200H	WS5270H	WS5350H
Water valves	DN	20	20	20
Water pressure	kPa	50-300	50-300	50-300
Capacity at 250 kPa	l/min	70	70	70
Drain valve	∅ mm	75	75	75
Draining capacity	l/min	240	240	240
Steam valve	DN	20	20	20
Steam pressure	kPa	100-600	100-600	100-600
Gas valve	DN	20	20	20
Gas evacuation	∅ mm	125	125	125
Floor requirements				
Frequency of the dynamic force	Hz	15.2	15.2	15.2
Sound levels				
Airborne sound level	dB(A)	72	72	72
Heat emission				
% of installed power, max		3	3	3
Shipping data**				
	net, kg	670	710	770
Shipping volume	m ³	2.34	2.77	3.38
Dimensions in mm				
A	Width	895	1050	1270
B	Depth	1080	1090	1100
C	Height	1620	1620	1620
D		850	850	850
E		85	75	65
F		100	100	100
G		1435	1435	1435
H		275	275	275
1	Electrical connection	7	Liquid detergent inlet	
2	Cold hard water	8	Detergent container	
3	Hot water	9	Loading door	
4	Cold soft water	10	Control panel	
5	Steam connection	11	Air vent connection	
6	Drain			

* Other voltages available, see installation manual.

** Average data. Crated weight/shipping volume depends on configuration. Please contact logistics for exact measures.

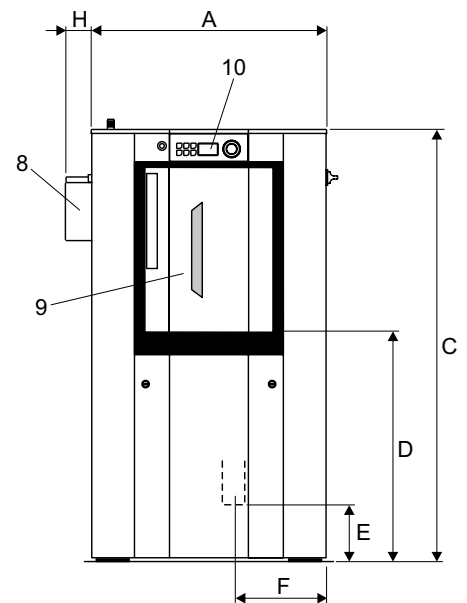

Front view

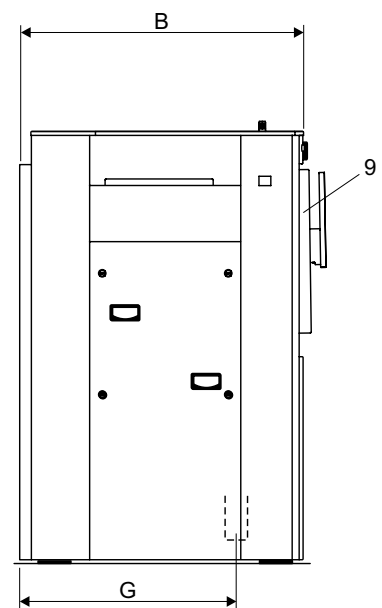

Side view

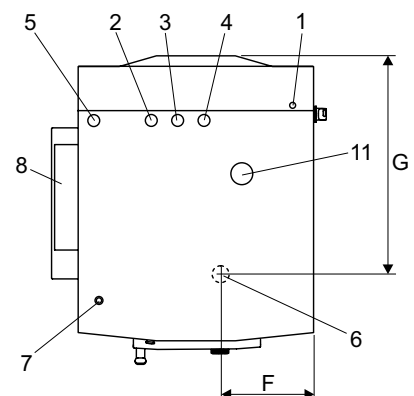

Top view